

PREASSEMBLY WORKSHEET & COMPONENT HEIGHT GUIDE

The Table below and accompanying illustrations on the following page can be used in two ways: 1) If Morrell Industries, Inc is going to pre-assemble your Mobile WorkCenter, fill out the table and send it to your Sales Representative. 2) The information can be used to help you understand Mobile WorkCenter composition and assembly.

Please fill in the "Desired Height" column. Morrell will install components according to these specifications. Your system will be shipped preassembled. Write "n/a" for items you will not be using.

Product	Height Range	Mounting Increments	Illustration Height	Desired Height
1. Monitor Platform	46.5"-51"	1"	47"	
2. Worksurface	16.5"-42.5"	1"	42.5"	
3a. (#1) 4" Drawer	15.5"-42.5"	1"	35.5"	
(#2) 4" Drawer	15.5"-42.5"	1"	35.5"	
(#3) 4" Drawer	15.5"-42.5"	1"	35.5"	
(#4) 4" Drawer	15.5"-42.5"	1"	35.5"	
(#5) 4" Drawer	15.5"-42.5"	1"	35.5"	
(#6) 4" Drawer	15.5"-42.5"	1"	35.5"	
3b. (#1) 8" Drawer	19.5"-42.5"	1"	n/a	
(#2) 8" Drawer	19.5"-42.5"	1"	n/a	
(#3) 8" Drawer	19.5"-42.5"	1"	n/a	
4. (#1) CPU Cabinet	20.3"-33.3"	1"	28.3"	
(#2) CPU Cabinet	20.3"-33.3"	1"	28.3"	
5. (#1) Server Shelf	11"-29"	2"	15.8"	
(#2) Server Shelf	11"-29"	2"	15.8"	
(#3) Server Shelf	11"-29"	2"	15.8"	
(#4) Server Shelf	11"-29"	2"	15.8"	
(#5) Server Shelf	11"-29"	2"	15.8"	
6. 15" Tower Shelf/UPS Cover**	10.6"***	n/a	10.6"	
7. 19" Tower Shelf**	7.5", 10.6"***	(choose one)	7.5"	
8. Bar Footrest	8.6" or 9.9"	(choose one)	9.9"	
9. Platform Footrest**	8.8"	n/a	8.8"	
10. UPS Holder**	10.5"	n/a	10.5"	
11. Cable Winding Bracket		(choose location)		

Other Components/Notes:

Circle mounting location for Bracket:
 Center horizontal frame rail
 Lower horizontal frame rail
 Back of Server Shelf
 Back of UPS Holder
 Back of 15" Tower Shelf
 Back of 19" Tower Shelf
 Back of Drawer Cover

* All heights measured from the ground to the top of the component surface, except for the Server Shelf (it is measured from the ground to its bottom surface). Ask your Sales Representative to see the Installation Manual for further details.
 ** These items are fixed in height and may not be adjusted.
 *** 15" Tower Shelf Mounted at 10.6" requires the UPS Holder or Platform Footrest
 19" Tower Shelf Mounted at 10.6" requires the UPS Holder. (Cannot be used with Platform Footrest).



COMPONENT HEIGHT GUIDE

All heights are measured from the ground to the top of the component surface. Exception: Server Shelf (it is measured from the ground to its bottom surface). Ask your Sales Representative to see the Installation Manual for further details.

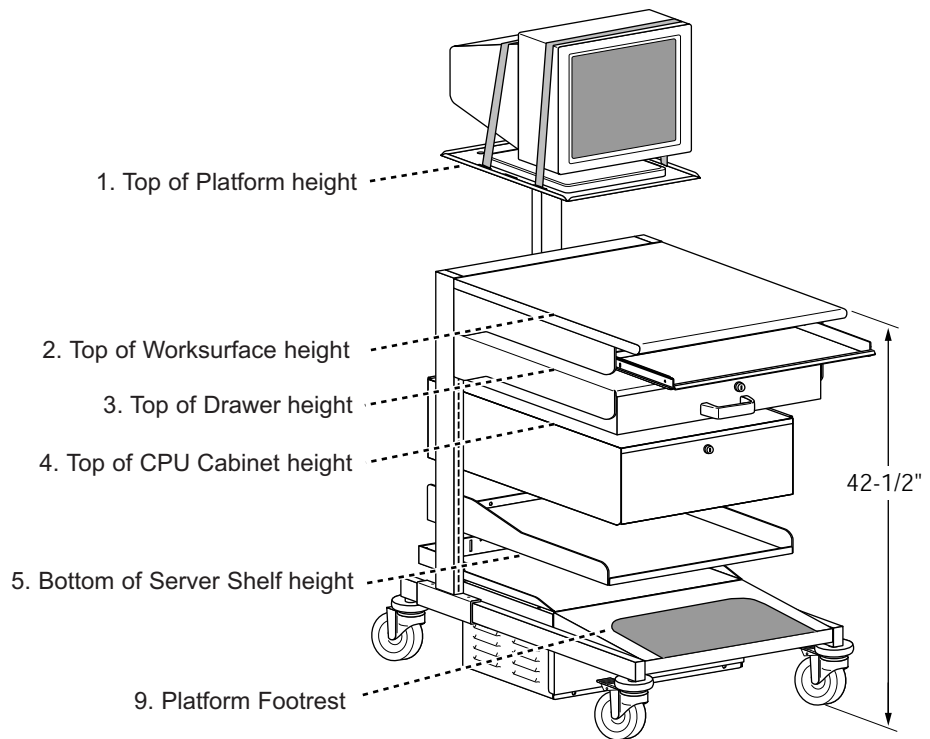

Rear view of Mobile WorkCenter

