

Glide Mount Security Bracket

Made in the U.S.A.

Read these instructions carefully and follow all steps in sequence

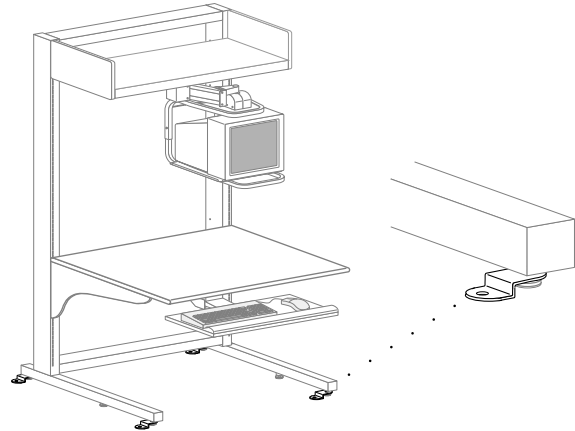

1. Install Glide up through Security Bracket and into Leg as shown in Figure 1.
2. Position your WorkCenter as required and fasten Bracket to floor using fasteners which are appropriate for your floor type.

NOTE:

If adjacent LANscape Organizer 3000 Legs are bolted together, only two Glide Mount Brackets may be needed per joined Legs. See Detail 1.

Note:

Hole size in Bracket allows use of up to $\varnothing 1/2$ " threaded rod, concrete anchor bolts or lag bolts.

CAUTION

Security Brackets must be securely anchored to the floor. Since Morrell Industries, Inc has no control over the type of floor and /or the ultimate fastening method, the user assumes all responsibility for this aspect of the installation. If you have any questions in regard to your anchoring system, see your building contractor.

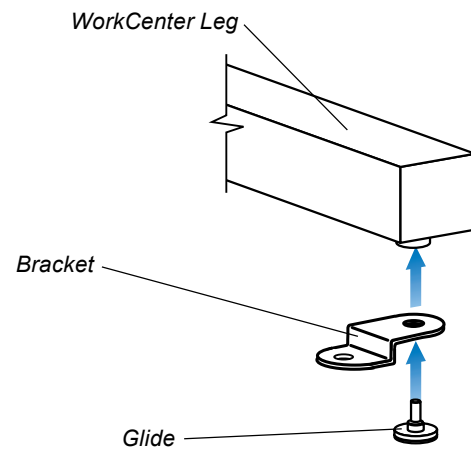
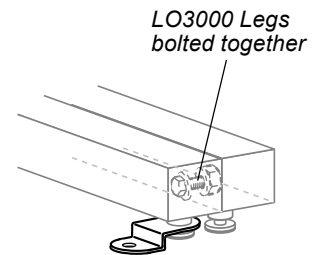

Figure 1



Detail 1

Glide Mount Security Bracket (cont)

Part Number	Description	Dimensions H x W x L
MILTS-60001-XX	Glide Mount Security Brckts, includes (4) brackets (enough for 4 Glides)	.78" x 1.25" x 3.1" (19.8 x 31.8 x 78.7mm)

Construction: 7 GA steel

Hole Size: \varnothing .531" (13.5mm), this hole is provided for use with up to 1/2" (12.7mm) threaded rod to anchor bracket through panel floors, concrete anchors or lag bolts.

C/L of Glide to anchor hole: 2.07" (52.6mm)



8683 Virginia Meadows Drive · Manassas, VA 20109
800-994-3002 · in VA: 703-369-2002
Fax: 703-257-9047 · www.morrellindustries.com

Specifications and prices subject to change without notice.

Reproduction of this material in whole or part for any purpose other than that authorized by Morrell Industries, Inc. is prohibited.

© 2006 Morrell Industries, Inc. All rights reserved.