

COMPONENTS	DESCRIPTION	MSRP	COMPONENTS	DESCRIPTION	MSRP
DuraFrame					
MILTS-10063-xx	30"W x 77"H DuraFrame	397	MILTS-80065-xx	1 - 12" Pull-Out Tower Holder	247
MILTS-10095-xx	30"W x 84"H DuraFrame	418	MILTS-80064-xx	1 - 18" Pull-Out Tower Holder	268
MILTS-10065-xx	42"W x 77"H DuraFrame	450	MILTS-80074-xx	4 - 12" & 1 - 18" Pull-Out Tower Holder	846
MILTS-10096-xx	42"W x 84"H DuraFrame	472	MILTS-60160-xx	12" L-Bracket/Slide (for p/o Tower)	69
Legs (w/ Casters&Glides)					
MILTS-17040-xx	34"L Legs, pair	225	MILTS-60161-xx	18" L-Bracket/Slide (for p/o Tower)	76
MILTS-17041-xx	6" Center Leg, for Dual Frame	40	MILTS-70065-xx	Cable Routing Mgmt (for p/o Tower)	46
MILTS-72021-xx	Glides, set of 6	16	Monitor Mounting		
MILTS-72008-xx	Glide, one	3	MIFPA-45400-xx	Suspension Mount Flat Panel Arm	288
MILTS-72022-xx	Casters, set of 6	134	MILTS-42021-xx	Suspension Truck	52
MILTS-72003-xx	Caster, one	22	MILTS-60230-xx	Inside Frame Mount Bracket Kit	95
MILTS-60001-xx	Glide Mount Security Brackets	71	MILTS-60231-xx	Front Frame Mount Bracket Kit	104
MILTS-97058-xx	Caster Mount Security Brackets	81	Rack Mount Options		
Worksurface/Underbracing					
MILTS-55008-xx	30"W x 30"D Worksurface	159	MILTS-60110-xx	19" Brackets (7"H)(for 30"W Frame)	88
MILTS-55019-xx	30"W x 36"D Worksurface	196	MILTS-60112-xx	19" Ext Brackets (7"H)(for 30"W Frame)	98
MILTS-55009-xx	42"W x 30"D Worksurface	196	MILTS-60111-xx	19" Brackets (7"H)(for 42"W Frame)	109
MILTS-55020-xx	42"W x 36"D Worksurface	236	MILTS-60113-xx	19" Ext Brackets (7"H)(for 42"W Frame)	134
MILTS-65069-xx	Cantilever Bracing, Single Frame	229	MILTS-57002-xx	19" Rack Add-on (14U)	533
MILTS-65070-xx	Cantilever Bracing, Dual Frame	275	Cable Management		
MILTS-60531-xx	Side/Backstop, for 30"W Worksurface	142	MILTS-70069-xx	18"L Quik-Touch Cable Management	20
MILTS-60532-xx	Side/Backstop, for 42"W Worksurface	155	MILTS-70068-xx	24"L Quik-Touch Cable Management	25
Storage Option					
MILTS-50048-xx	30"W x 20"D Server Shelf	175	MILTS-70067-xx	36"L Quik-Touch Cable Management	30
MILTS-50170-xx	30"W x 27"D Deep Server Shelf	289	MILTS-97004-xx	Worksurface Mounting Bracket (Pair)	36
MILTS-50120-xx	30"W x 12"D Peripheral Shelf	134	MILTS-60268-xx	Frame Mounting Bracket (for 30" Frame)	61
MILTS-50111-xx	30"W x 20"D Tilt Server Shelf	286	MILTS-60269-xx	Frame Mounting Bracket (for 42" Frame)	67
MILTS-53062-xx	30"W x 18"D Suspension Shelf	299	Keyboard/Laptop Solutions		
MILTS-50049-xx	42"W x 20"D Server Shelf	216	MILTS-75038-xx	Articulating Keyboard Arm (w/ lever)	155
MILTS-50171-xx	42"W x 27"D Deep Server Shelf	330	MILTS-77086-xx	Kybd/Mouse Tray (for MILTS-75038-xx)	101
MILTS-50121-xx	42"W x 12"D Peripheral Shelf	165	MILTS-75040-xx	Articulating Laptop Arm	238
MILTS-50112-xx	42"W x 20"D Tilt Server Shelf	339	MILTS-75052-xx	Wire Keyboard Holder (mounts to shelf)	63
MILTS-53063-xx	42"W x 18"D Suspension Shelf	330	MILTS-75054-xx	Adj Kybd Tray Holder (mounts to shelf)	63
MILTS-50051-xx	72"W x 20"D Server Shelf	432	MILTS-77050-xx	Kybd Tray w/ Sliding Mouse & Wrist Rest	97
MILTS-50137-xx	72"W x 12"D Peripheral Shelf (N/S)	278	Power/Accessories		
MILTS-50025-xx	72"W x 20"D Tilt Server Shelf (N/S)	477	MIPWR-83001-xx	16-outlet Power Strip (48"L)(15AMP)	87
MILTS-53065-xx	72"W x 18"D Suspension Shelf	485	MIPWR-83112-xx	7-outlet surge suppressor (15AMP)	78
MILTS-60042-xx	Center Support Brace (for Dual Frame)	48	MIPWR-83125-xx	8-outlet power strip (24"L)(H-mount)	77
MILTS-60353-xx	Single side panel for (Deep Server Shelf)	30	MIPWR-83126-xx	12-outlet power strip (36"L)(H-mount)	97
MILTS-50114-xx	26"W x 6"D Shelf Ext (for 30"W Frame)	78	MILTS-82004-xx	24" Task Light (shelf mount)	134
MILTS-50115-xx	38"W x 6"D Shelf Ext (for 42"W Frame)	90	MILTS-82005-xx	33" Task Light (shelf mount)	144
MILTS-60136-xx	Shelf Backstop (for 30"W Shelf)	34	Select Color Options:		
MILTS-60137-xx	Shelf Backstop (for 42"W Frame)	39	PAINT	LAMINATE	Ex:
MILTS-50078-xx	30"W x 27"D Fixed Tower Holder	213	GY - Grey	GY - Grey Nebula	MILTS-55008-BK
MILTS-50079-xx	42"W x 27"D Fixed Tower Holder	235	BK - Black	BK - Black Marble	MILTS-65069-GY
MILTS-50081-xx	72"W x 27"D Fixed Tower Shelf	392			

Custom Paints and Laminates available upon request
N/S - Non-Standard, minimum order quantities may apply

39 PRECONFIGURED SOLUTIONS GUIDE

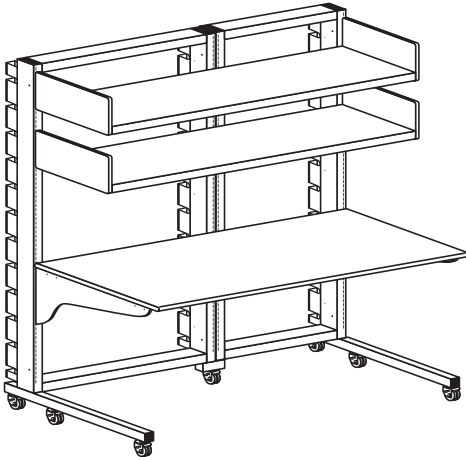



Assembly Number: MILTS-27220-GY

Dimensions: 72" W x 77 3/16" H x 37" D

Shipping Wt: 440

Weight Capacity: 3500 lbs

Color of Worksurface: Grey Nebula

Color of DuraFrame: Grey

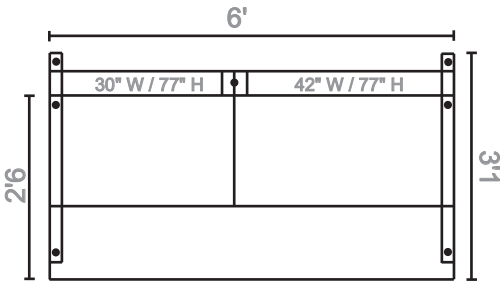

Qt	Parts	Description	MSRP	Ext
1	MILTS-10063-GY	30"W x 77"H Duraframe	397	397
1	MILTS-10065-GY	42"W x 77"H Duraframe	450	450
1	MILTS-17040-GY	34"L Legs, pair	225	225
1	MILTS-17041-GY	Center Leg, for Dual Frame	40	40
1	MILTS-72022-XX	Casters, set of 6	134	134
1	MILTS-72003-XX	Caster, one	22	22
1	MILTS-55015-GY	72"W x 30"D Worksurface	262	262
1	MILTS-65070-GY	Cantilever Bracing, Dual Frame	275	275
2	MILTS-50051-GY	72"W x 20"D Server Shelf	432	864
8	MILTS-70067-GY	36"L Quik-Touch Cable Management	30	240
2	MILTS-70068-GY	24"L Quik-Touch Cable Management	25	50
1	MIPWR-83125-XX	8-outlet power strip (24"L)(H-mount)	77	77
Total:			3036	

Product Highlights

- Up to 4,500 lbs (2,043 kg) weight capacity keeps equipment safe
- Organize your equipment and tools for convenient access
- Easy assembly and modularity allows you to add additional units to create multiple workstations
- Front and Rear mounting slots allow component adjustability in 1- inch increments on both sides of frame
- Server shelves easily hold up to 500 pounds of equipment.
- Lockable casters enable quick system relocation
- All frame-mounted components have safety lock features
- Patented Quik-Touch cable management system, individually hinged sections to provide one-touch access.
- Rugged, durable construction and an Industry-leading warranty

Assembly Number: MILTS-27721-GY

Dimensions: 72" W x 77 3/16" H x 37" D

Shipping Wt: 539

Weight Capacity: 4500 lbs

Color of Worksurface: Grey Nebula

Color of DuraFrame: Grey

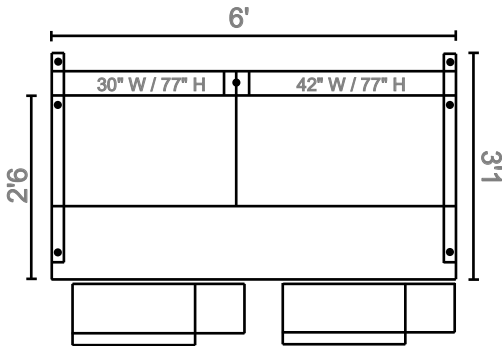
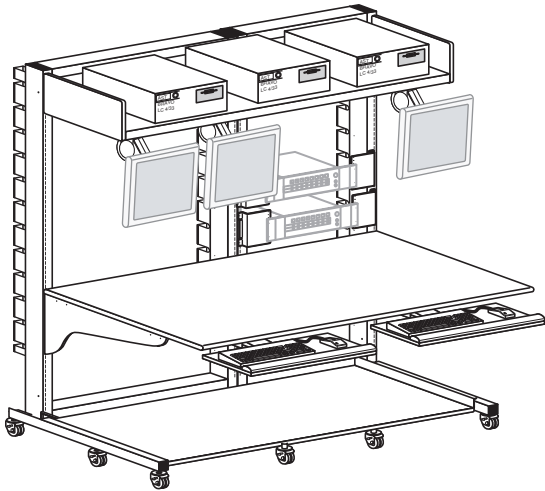

Qt	Parts	Description	MSRP Ext	
1	MILTS-10063-GY	30"W x 77"H Duraframe	397	397
1	MILTS-10065-GY	42"W x 77"H Duraframe	450	450
1	MILTS-17040-GY	34"L Legs, pair	225	225
1	MILTS-17041-GY	Center Leg, for Dual Frame	40	40
1	MILTS-72022-XX	Casters, set of 6	134	134
3	MILTS-72003-XX	Caster, one	22	66
1	MILTS-55015-GY	72"W x 30"D Worksurface	262	262
1	MILTS-65070-GY	Cantilever Bracing, Dual Frame	275	275
1	MILTS-53065-GY	72"W x 20"D Suspension Shelf	485	485
3	MIFPA-45400-GY	Suspension Mount Flat Panel Arm	288	864
3	MILTS-42021-GY	Suspension Truck (for MIFPA-45400)	52	156
2	MILTS-60110-GY	19" Brackets (7"H)(for 30"W Frame)	88	176
2	MILTS-75038-BK	Articulating Keyboard Arm (w/lever)	155	310
2	MILTS-77086-BK	Kybd/Mouse Tray (for MILTS-75038)	101	202
1	MILTS-50081-GY	30"W x 27"D Fixed Tower Holder	392	392
8	MILTS-70067-GY	36"L Quik-Touch Cable Management	30	240
2	MILTS-70068-GY	24"L Quik-Touch Cable Management	25	50
1	MIPWR-83125-XX	8-outlet power strip (24"L)(H-mount)	77	77
Total:			4801	

Product Highlights

- Suspended flat panel monitor allows easy adjustment by operator
- Articulating rotating keyboard arm with mouse tray increases ergonomic comfort
- Fixed tower shelf mounts on legs to provide sturdy heavy duty storage off the floor
- Organize your equipment and tools for convenient access
- Easy assembly and modularity allows you to add additional units to create multiple workstations
- Front and Rear mounting slots allow component adjustability in 1- inch increments on both sides of frame
- Server shelves easily hold up to 500 pounds of equipment.
- Lockable casters enable quick system relocation
- All frame-mounted components have safety lock features
- Patented Quik-Touch cable management system, individually hinged sections to provide one-touch access.
- Rugged, durable construction and an Industry-leading warranty

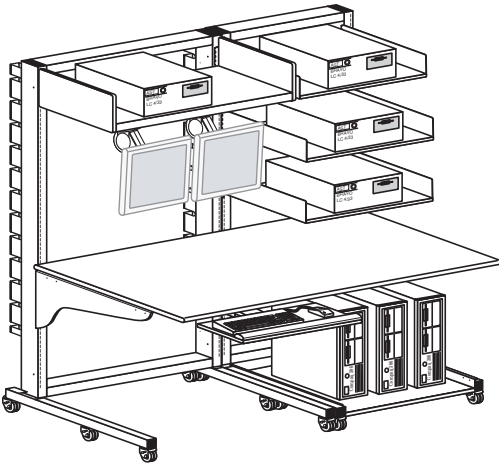

Assembly Number: MILTS-27722-GY

Dimensions: 72" W x 77 3/16" H x 37" D

Shipping Wt: 572

Weight Capacity: 4500 lbs

Color of Worksurface: Grey Nebula

Color of DuraFrame: Grey

Qt	Parts	Description	MSRP Ext	
1	MILTS-10063-GY	30"W x 77"H Duraframe	397	397
1	MILTS-10065-GY	42"W x 77"H Duraframe	450	450
2	MILTS-17040-GY	34"L Legs, pair	225	450
2	MILTS-72022-XX	Casters, set of 6	134	268
1	MILTS-55015-GY	72"W x 30"D Worksurface	262	262
1	MILTS-65070-GY	Cantilever Bracing, Dual Frame	275	275
3	MILTS-50048-GY	30"W x 20"D Server Shelf	175	525
1	MILTS-50078-GY	30"W x 27"D Fixed Tower Shelf	213	213
1	MILTS-53063-GY	42"W x 18"D Suspension Shelf	330	330
2	MIFPA-45400-GY	Suspension Mount Flat Panel Arm	288	576
2	MILTS-42021-GY	Suspension Truck (for MIFPA-45400)	54	108
1	MILTS-75038-BK	Articulating Keyboard Arm (w/lever)	155	155
1	MILTS-77086-BK	Kybd/Mouse Tray (for MILTS-75038)	101	101
7	MILTS-70067-GY	36"L Quik-Touch Cable Management	30	210
2	MILTS-70068-GY	24"L Quik-Touch Cable Management	25	50
1	MIPWR-83125-XX	8-outlet power strip (24"L)(H-mount)	77	77
Total:			4447	

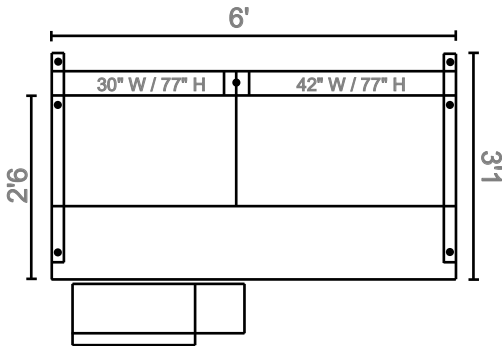

Product Highlights

- Suspended flat panel monitor allows easy adjustment by operator
- Articulating rotating keyboard arm with mouse tray increases ergonomic comfort
- Fixed tower shelf mounts on legs to provide sturdy heavy duty storage off the floor
- Organize your equipment and tools for convenient access
- Easy assembly and modularity allows you to add additional units to create multiple workstations
- Front and Rear mounting slots allow component adjustability in 1- inch increments on both sides of frame
- Server shelves easily hold up to 500 pounds of equipment.
- Lockable casters enable quick system relocation
- All frame-mounted components have safety lock features
- Patented Quik-Touch cable management system, individually hinged sections to provide one-touch access.
- Rugged, durable construction and an Industry-leading warranty