

<i>COMPONENTS</i>	<i>DESCRIPTION</i>	<i>MSRP</i>	<i>COMPONENTS</i>	<i>DESCRIPTION</i>	<i>MSRP</i>
DuraFrame					
MILTS-10065-xx	42"W x 77"H DuraFrame	450	MIFPA-45400-xx	Suspension Mount Flat Panel Arm	288
MILTS-10096-xx	42"W x 84"H DuraFrame	472	MILTS-42021-xx	Suspension Truck	52
Legs (w/ Casters&Glides)					
MILTS-17040-xx	34"L Legs, pair	225	MILTS-60230-xx	Inside Frame Mount Bracket Kit	95
MILTS-72021-xx	Glides, set of 6	16	MILTS-60231-xx	Front Frame Mount Bracket Kit	104
MILTS-72008-xx	Glide, one	3	Rack Mount Options		
MILTS-72022-xx	Casters, set of 6	134	MILTS-60111-xx	19" Brackets (7"H)(for 42"W Frame)	109
MILTS-72003-xx	Caster, one	22	MILTS-60113-xx	19" Ext Brackets (7"H)(for 42"W Frame)	134
MILTS-60001-xx	Glide Mount Security Brackets	71	Cable Management		
MILTS-97058-xx	Caster Mount Security Brackets	81	MILTS-70069-xx	18"L Quik-Touch Cable Management	20
Worksurface/Underbracing					
MILTS-55009-xx	42"W x 30"D Worksurface	196	MILTS-70068-xx	24"L Quik-Touch Cable Management	25
MILTS-55020-xx	42"W x 36"D Worksurface	236	MILTS-70067-xx	36"L Quik-Touch Cable Management	30
MILTS-65069-xx	Cantilever Bracing, Single Frame	229	MILTS-97004-xx	Worksurface Mounting Bracket (Pair)	36
MILTS-60532-xx	Side/Backstop, for 42"W Worksurface	155	MILTS-60269-xx	Frame Mounting Bracket (for 42" Frame)	67
Storage Options					
MILTS-50049-xx	42"W x 20"D Server Shelf	216	Keyboard/Laptop Solutions		
MILTS-50171-xx	42"W x 27"D Deep Server Shelf	330	MILTS-75038-xx	Articulating Keyboard Arm (w/ lever)	155
MILTS-50121-xx	42"W x 12"D Peripheral Shelf	165	MILTS-77086-xx	Kybd/Mouse Tray (for MILTS-75038-xx)	101
MILTS-50112-xx	42"W x 20"D Tilt Server Shelf	339	MILTS-75040-xx	Articulating Laptop Arm	238
MILTS-53063-xx	42"W x 18"D Suspension Shelf	330	MILTS-75052-xx	Wire Keyboard Holder (mounts to shelf)	63
MILTS-60353-xx	Single side panel for (MILTS-50171-xx)	30	MILTS-75054-xx	Adj Kybd Tray Holder (mounts to shelf)	63
MILTS-50115-xx	38"W x 6"D Shelf Ext (for 42"W Frame)	90	MILTS-77050-xx	Kybd Tray w/ Sliding Mouse & Wrist Rest	97
MILTS-60137-xx	Shelf Backstop (for 42"W Frame)	39	Power/Accessories		
MILTS-50079-xx	42"W x 27"D Fixed Tower Holder	235	MIPWR-83001-xx	16-outlet Power Strip (48"L)(15AMP)	87
MILTS-80065-xx	1 - 12" Pull-Out Tower Holder	247	MIPWR-83112-xx	7-outlet surge suppressor (15AMP)	78
MILTS-80064-xx	1 - 18" Pull-Out Tower Holder	268	MIPWR-83125-xx	8-outlet power strip (24"L)(H-mount)	77
MILTS-80072-xx	2 - 18" Pull-Out Tower Holder	494	MIPWR-83126-xx	12-outlet power strip (36"L)(H-mount)	97
MILTS-60160-xx	12" L-Bracket/Slide (for p/o Tower)	69	MILTS-82005-xx	33" Task Light (shelf mount)	144
MILTS-70065-xx	Cable Routing Mgmt (for p/o Tower)	46	Select Color Options:		
MILTS-95014-xx	42"W Lockable Security Cabinet	619	PAINT	LAMINATE	Ex:
MILTS-68007-xx	Organizer Drawer	57	GY - Grey	GYNEB - Grey Nebula	MILTS-55009-BK
MILTS-68121-xx	Mobile Pedestal File (Box/Box/File)	485	BK - Black	BK - Black Marble	MILTS-65069-GY
MILTS-68122-xx	Mobile Pedestal File (File/File)	485	Custom Paints and Laminates available upon request		

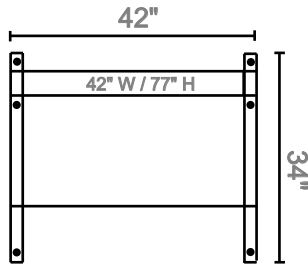

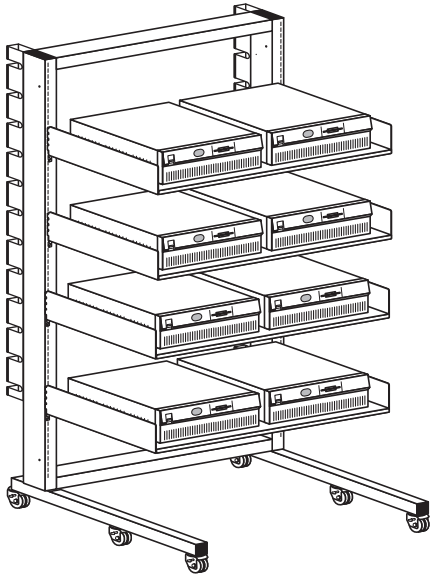

Assembly Number: MILTS-27421-GY

Dimensions: 42"W x 77 3/16"H x 34"D

Shipping Wt: 298

Weight Capacity: 1250 lbs

Color of Worksurface: None

Color of DuraFrame: Grey

Qt	Parts	Description	MSRP	Ext
1	MILTS-10065-GY	42"W x 77"H Duraframe	450	450
1	MILTS-17040-GY	34"L Legs, pair	225	225
1	MILTS-72022-XX	Casters, set of 6	134	134
4	MILTS-50049-GY	42"W x 20"D Server Shelf	216	864
1	MIACC-99045-GY	Hook Spacer Kit	12	12
8	MILTS-70067-GY	36"L Quik-Touch Cable Management	30	240
1	MIPWR-83126-XX	12-outlet Power Strip (36"L)(H-mount)	97	97
Total:				2022

Product Highlights

- Up to 4,500 lbs (2,043 kg) weight capacity keeps equipment safe
- Organize your equipment and tools for convenient access
- Easy assembly and modularity allows you to add additional units to create multiple workstations
- Front and Rear mounting slots allow component adjustability in 1- inch increments on both sides of frame
- Server shelves easily hold up to 500 pounds of equipment.
- Lockable casters enable quick system relocation
- All frame-mounted components have safety lock features
- Patented Quik-Touch cable management system, individually hinged sections to provide one-touch access.
- Rugged, durable construction and an Industry-leading warranty

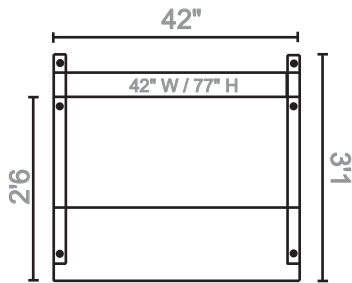
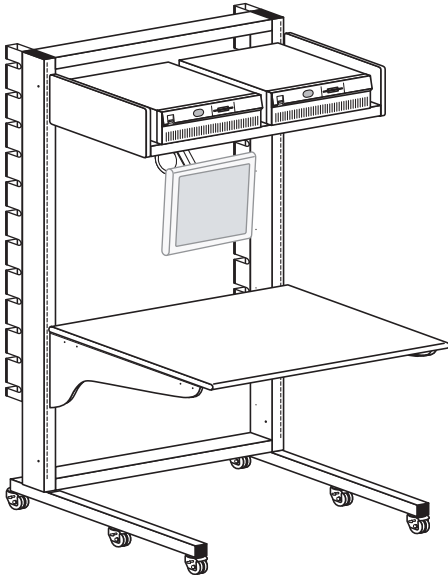

Assembly Number: MILTS-27422-GY

Dimensions: 42"W x 77 3/16"H x 37"D

Shipping Wt: 272

Weight Capacity: 1250 lbs

Color of Worksurface: Grey Nebula

Color of DuraFrame: Grey

Qt	Parts	Description	MSRP	Ext
1	MILTS-10065-GY	42"W x 77"H Duraframe	450	450
1	MILTS-17040-GY	34"L Legs, pair	225	225
1	MILTS-72022-XX	Casters, set of 6	134	134
1	MILTS-55009-GY	42"W x 30"D Worksurface	196	196
1	MILTS-65069-GY	Cantilever Bracing, Single Frame	229	229
1	MILTS-53063-GY	42"W x 18"D Suspension Shelf	330	330
1	MIFPA-45400-GY	Suspension Mount Flat Panel Arm	288	288
1	MILTS-42021-GY	Suspension Truck (for MIFPA-45400)	52	52
8	MILTS-70067-GY	36"L Quik-Touch Cable Management	30	240
1	MIPWR-83126-XX	12-outlet Power Strip (36"L)(H-mount)	97	97
Total:			2241	2241

Product Highlights

- Suspended flat panel monitor allows easy adjustment by operator
- Up to 4,500 lbs (2,043 kg) weight capacity keeps equipment safe
- Organize your equipment and tools for convenient access
- Easy assembly and modularity allows you to add additional units to create multiple workstations
- Front and Rear mounting slots allow component adjustability in 1- inch increments on both sides of frame
- Server shelves easily hold up to 500 pounds of equipment.
- Lockable casters enable quick system relocation
- All frame-mounted components have safety lock features
- Patented Quik-Touch cable management system, individually hinged sections to provide one-touch access.
- Rugged, durable construction and an Industry-leading warranty

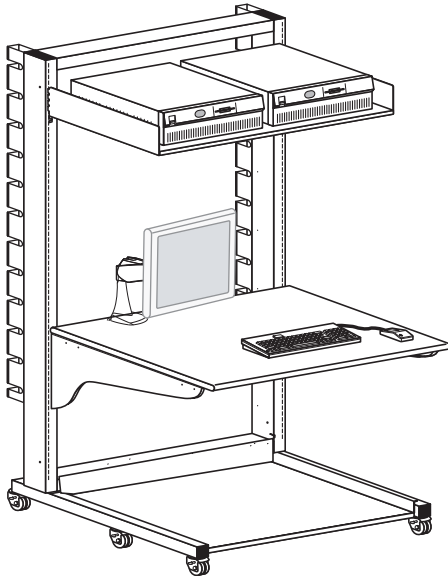

Assembly Number: MILTS-27423-GY

Dimensions: 42"W x 77 3/16"H x 37"D

Shipping Wt: 299

Weight Capacity: 2550 lbs

Color of Worksurface: Grey Nebula

Color of DuraFrame: Grey

Qt	Parts	Description	MSRP	Ext
1	MILTS-10065-GY	42"W x 77"H Duraframe	450	450
1	MILTS-17040-GY	34"L Legs, pair	225	225
1	MILTS-72022-XX	Casters, set of 6	134	134
1	MILTS-55009-GY	42"W x 30"D Worksurface	196	196
1	MILTS-65069-GY	Cantilever Bracing, Single Frame	229	229
1	MILTS-50049-GY	42"W x 20"D Server Shelf	216	216
1	MILTS-50079-GY	42"W x 27"D Fixed Tower Holder	235	235
1	MIFPA-45601-GY	Flat Panel Desk Mount w/ Ext	288	288
8	MILTS-70067-GY	36"L Quik-Touch Cable Management	30	240
1	MIPWR-83126-XX	12-outlet Power Strip (36"L)(H-mount)	97	97
Total:			2310	

Product Highlights

- Desk mount flat panel arm provides easy adjustability and access to a cleaner worksurface
- Fixed tower shelf mounts on legs to provide sturdy heavy duty storage off the floor
- Up to 4,500 lbs (2,043 kg) weight capacity keeps equipment safe
- Organize your equipment and tools for convenient access
- Easy assembly and modularity allows you to add additional units to create multiple workstations
- Front and Rear mounting slots allow component adjustability in 1- inch increments on both sides of frame
- Server shelves easily hold up to 500 pounds of equipment.
- Lockable casters enable quick system relocation
- All frame-mounted components have safety lock features
- Patented Quik-Touch cable management system, individually hinged sections to provide one-touch access.
- Rugged, durable construction and an Industry-leading warranty

