

<i>COMPONENTS</i>	<i>DESCRIPTION</i>	<i>MSRP</i>	<i>COMPONENTS</i>	<i>DESCRIPTION</i>	<i>MSRP</i>
<b>DuraFrame</b>			<b>Monitor Mounting</b>		
MILTS-10063-xx	30"W x 77"H DuraFrame	397	MIFPA-45400-xx	Suspension Mount Flat Panel Arm	288
MILTS-10095-xx	30"W x 84"H DuraFrame	418	MILTS-42021-xx	Suspension Truck	54
<b>Legs (w/ Casters&amp;Glides)</b>			MILTS-60230-xx	Inside Frame Mount Bracket Kit	95
MILTS-17040-xx	34"L Legs, pair	225	MILTS-60231-xx	Front Frame Mount Bracket Kit	104
MILTS-72021-xx	Glides, set of 6	16	<b>Rack Mount Options</b>		
MILTS-72008-xx	Glide, one	3	MILTS-60110-xx	19" Brackets (7"H)(for 30"W Frame)	88
MILTS-72022-xx	Casters, set of 6	134	MILTS-60112-xx	19" Ext Brackets (7"H)(for 30"W Frame)	98
MILTS-72003-xx	Caster, one	22	MILTS-57002-xx	19" Rack Add-on (14U)	533
MILTS-60001-xx	Glide Mount Security Brackets	71	<b>Cable Management</b>		
MILTS-97058-xx	Caster Mount Security Brackets	81	MILTS-70069-xx	18"L Quik-Touch Cable Management	20
<b>Worksurface/Underbracing</b>			MILTS-70068-xx	24"L Quik-Touch Cable Management	25
MILTS-55008-xx	30"W x 30"D Worksurface	159	MILTS-70067-xx	36"L Quik-Touch Cable Management	30
MILTS-55019-xx	30"W x 36"D Worksurface	196	MILTS-97004-xx	Worksurface Mounting Bracket (Pair)	36
MILTS-65069-xx	Cantilever Bracing, Single Frame	229	MILTS-60268-xx	Frame Mounting Bracket (for 30" Frame)	61
MILTS-60531-xx	Side/Backstop, for 30"W Worksurface	142	<b>Keyboard/Laptop Solutions</b>		
<b>Storage Option</b>			MILTS-75038-xx	Articulating Keyboard Arm (w/ lever)	155
MILTS-50048-xx	30"W x 20"D Server Shelf	175	MILTS-77086-xx	Kybd/Mouse Tray (for MILTS-75038-xx)	101
MILTS-50170-xx	30"W x 27"D Deep Server Shelf	289	MILTS-75040-xx	Articulating Laptop Arm	238
MILTS-50120-xx	30"W x 12"D Peripheral Shelf	134	MILTS-75052-xx	Wire Keyboard Holder (mounts to shelf)	63
MILTS-50111-xx	30"W x 20"D Tilt Server Shelf	286	MILTS-75054-xx	Adj Kybd Tray Holder (mounts to shelf)	63
MILTS-53062-xx	30"W x 18"D Suspension Shelf	299	MILTS-77050-xx	Kybd Tray w/ Sliding Mouse & Wrist Rest	97
MILTS-60353-xx	Single side panel for (MILTS-50170-xx)	30	<b>Power/Accessories</b>		
MILTS-50114-xx	26"W x 6"D Shelf Ext (for 30"W Frame)	78	MIPWR-83001-xx	16-outlet Power Strip (48"L)(15AMP)	87
MILTS-60136-xx	Shelf Backstop (for 30"W Shelf)	34	MIPWR-83006-xx	6-outlet surge suppressor (14"L)(15AMP)	78
MILTS-50078-xx	30"W x 27"D Fixed Tower Holder	213	MIPWR-83112-xx	7-outlet surge suppressor (15AMP)	78
MILTS-80071-xx	2 - 12" Pull-Out Tower Holder	434	MIPWR-83125-xx	8-outlet power strip (24"L)(H-mount)	77
MILTS-60160-xx	12" L-Bracket/Slide (for p/o Tower)	69	MIPWR-83215-FR	14-outlet surge suppressor (6 front, 8 rear)	85
MILTS-70065-xx	Cable Routing Mgmt (for p/o Tower)	46	MILTS-82004-xx	24" Task Light (shelf mount)	134
MILTS-95011-xx	30"W Lockable Security Cabinet	514	<b>Select Color Options:</b>		
MILTS-68007-xx	Organizer Drawer	57	PAINT	LAMINATE	Ex:
MILTS-68121-xx	Mobile Pedestal File (Box/Box/File)	485	GY - Grey	GyNeb - Grey Nebula	MILTS-55008-BK
MILTS-68122-xx	Mobile Pedestal File (File/File)	485	BK - Black	BK - Black Marble	MILTS-65069-GY

Custom Paints and Laminates available upon request

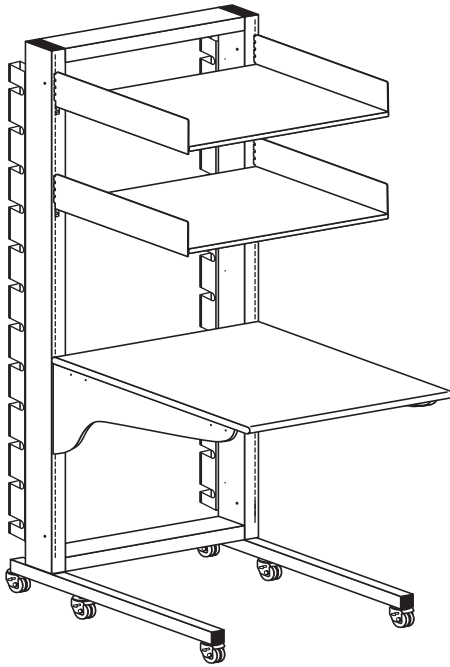



**Assembly Number: MILTS-27216-GY**

Dimensions: 30" W x 77 3/16" H x 37" D

Shipping Wt: 241

Weight Capacity: 4500 lbs

Color of Worksurface: Grey Nebula

Color of DuraFrame: Grey

Qt	Parts	Description	MSRP Ext	
1	MILTS-10063-GY	30"W x 77"H Duraframe	397	397
1	MILTS-17040-GY	34"L Legs, pair	225	225
1	MILTS-72022-XX	Casters, set of 6	134	134
1	MILTS-55008-GY	30"W x 30"D Worksurface	159	159
1	MILTS-65069-GY	Cantilever Bracing, Single Frame	229	229
2	MILTS-50048-GY	30"W x 20"D Server Shelf	175	350
1	MIACC-99045-GY	Hook Spacer Kit	12	12
6	MILTS-70067-GY	36"L Quik-Touch Cable Management	30	180
4	MILTS-70068-GY	24"L Quik-Touch Cable Management	25	100
1	MIPWR-83125-XX	8-outlet power strip (24"L)(H-mount)	77	77
<b>Total:</b>			<b>1863</b>	

**Product Highlights**

- Up to 4,500 lbs (2,043 kg) weight capacity keeps equipment safe
- Organize your equipment and tools for convenient access
- Easy assembly and modularity allows you to add additional units to create multiple workstations
- Front and Rear mounting slots allow component adjustability in 1- inch increments on both sides of frame
- Server shelves easily hold up to 500 pounds of equipment.
- Lockable casters enable quick system relocation
- All frame-mounted components have safety lock features
- Patented Quik-Touch cable management system, individually hinged sections to provide one-touch access.
- Rugged, durable construction and an Industry-leading warranty

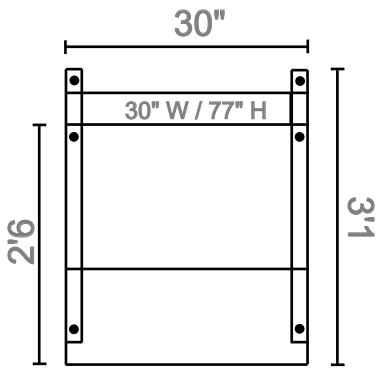

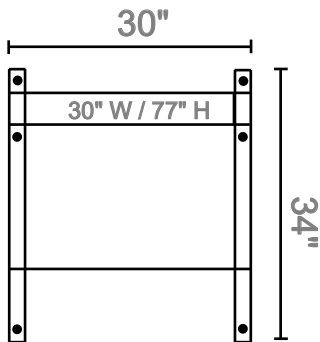
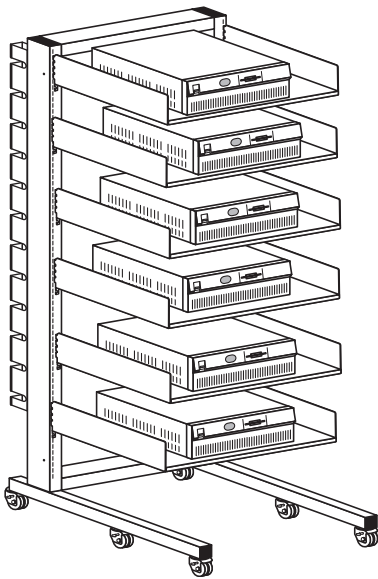

**Assembly Number: MILTS-27301-GY**

Dimensions: 30"W x 77 3/16"H x 34"D

Shipping Wt: 312

Weight Capacity: 1250 lbs

Color of Worksurface: None

Color of DuraFrame: Grey

Qt	Parts	Description	MSRP Ext	
1	MILTS-10063-GY	30"W x 77"H Duraframe	397	397
1	MILTS-17040-GY	34"L Legs, pair	225	225
1	MILTS-72022-XX	Casters, set of 6	134	134
6	MILTS-50048-GY	30"W x 20"D Server Shelf	175	1050
2	MIACC-99045-GY	Hook Spacer Kit	12	24
6	MILTS-70067-GY	36"L Quik-Touch Cable Management	30	180
4	MILTS-70068-GY	24"L Quik-Touch Cable Management	25	100
1	MIPWR-83125-XX	8-outlet power strip (24"L)(H-mount)	77	77
<b>Total:</b>			<b>2187</b>	

**Product Highlights**

- Up to 4,500 lbs (2,043 kg) weight capacity keeps equipment safe
- Organize your equipment and tools for convenient access
- Easy assembly and modularity allows you to add additional units to create multiple workstations
- Front and Rear mounting slots allow component adjustability in 1- inch increments on both sides of frame
- Server shelves easily hold up to 500 pounds of equipment.
- Lockable casters enable quick system relocation
- All frame-mounted components have safety lock features
- Patented Quik-Touch cable management system, individually hinged sections to provide one-touch access.
- Rugged, durable construction and an Industry-leading warranty

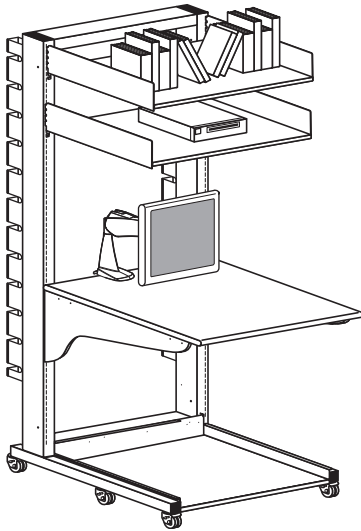

**Assembly Number: MILTS-27302-GY**

Dimensions: 30"W x 77 3/16"H x 37"D

Shipping Wt: 294

Weight Capacity: 3300 lbs

Color of Worksurface: Grey Nebula

Color of DuraFrame: Grey

Qt	Parts	Description	MSRP Ext	
1	MILTS-10063-GY	30"W x 77"H Duraframe	397	397
1	MILTS-17040-GY	34"L Legs, pair	225	225
1	MILTS-72022-XX	Casters, set of 6	134	134
1	MILTS-55008-GY	30"W x 30"D Worksurface	159	159
1	MILTS-65069-GY	Cantilever Bracing, Single Frame	229	229
1	MIFPA-45601-GY	Flat Panel Desk Mount w/ Ext	288	288
2	MILTS-50048-GY	30"W x 20"D Server Shelf	175	350
1	MILTS-50078-GY	30"W x 27"D Fixed Tower Shelf	213	213
1	MIACC-99045-GY	Hook Spacer Kit	12	12
6	MILTS-70067-GY	36"L Quik-Touch Cable Management	30	180
4	MILTS-70068-GY	24"L Quik-Touch Cable Management	25	100
1	MIPWR-83125-XX	8-outlet power strip (24"L)(H-mount)	77	77
<b>Total:</b>			<b>2364</b>	

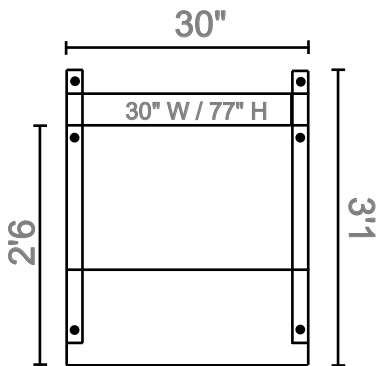

**Product Highlights**

- Desk mount flat panel arm provides easy adjustability and access to a cleaner worksurface
- Fixed tower shelf mounts on legs to provide sturdy heavy duty storage off the floor
- Up to 4,500 lbs (2,043 kg) weight capacity keeps equipment safe
- Organize your equipment and tools for convenient access
- Easy assembly and modularity allows you to add additional units to create multiple workstations
- Front and Rear mounting slots allow component adjustability in 1- inch increments on both sides of frame
- Server shelves easily hold up to 500 pounds of equipment.
- Lockable casters enable quick system relocation
- All frame-mounted components have safety lock features
- Patented Quik-Touch cable management system, individually hinged sections to provide one-touch access.
- Rugged, durable construction and an Industry-leading warranty

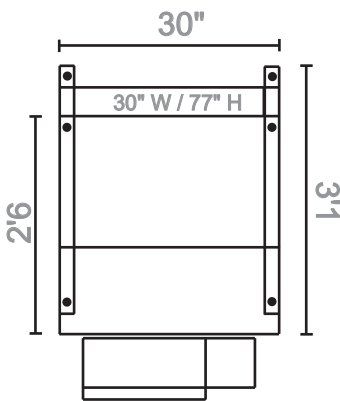
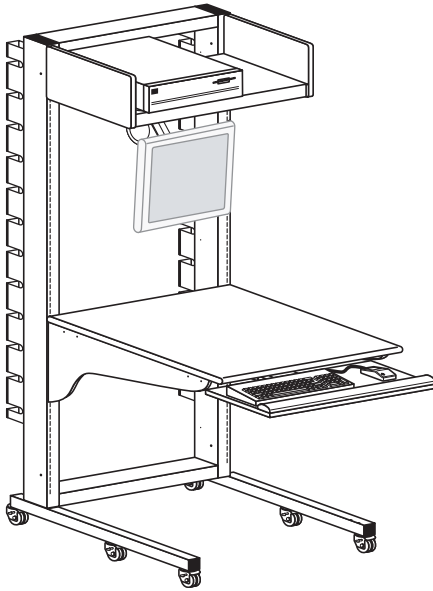

**Assembly Number: MILTS-27303-GY**

Dimensions: 30"W x 77 3/16"H x 34"D

Shipping Wt: 265

Weight Capacity: 1250 lbs

Color of Worksurface: Grey Nebula

Color of DuraFrame: Grey

Qt	Parts	Description	MSRP Ext	
1	MILTS-10063-GY	30"W x 77"H Duraframe	397	397
1	MILTS-17040-GY	34"L Legs, pair	225	225
1	MILTS-72022-XX	Casters, set of 6	134	134
1	MILTS-55008-GY	30"W x 30"D Worksurface	159	159
1	MILTS-65069-GY	Cantilever Bracing, Single Frame	229	229
1	MILTS-75038-BK	Articulating Keyboard Arm (w/lever)	155	155
1	MILTS-77086-BK	Kybd/Mouse Tray (for MILTS-75038)	101	101
1	MILTS-53062-GY	30"W x 18"D Suspension Shelf	299	299
1	MIFPA-45400-GY	Suspension Mount Flat Panel Arm	288	288
1	MILTS-42021-GY	Suspension Truck (for MIFPA-45400)	54	54
6	MILTS-70067-GY	36"L Quik-Touch Cable Management	30	180
4	MILTS-70068-GY	24"L Quik-Touch Cable Management	25	100
1	MIPWR-83125-XX	8-outlet power strip (24"L)(H-mount)	77	77
<b>Total:</b>			<b>2398</b>	

**Product Highlights**

- Suspended flat panel monitor allows easy adjustment by operator
- Articulating rotating keyboard arm with mouse tray increases ergonomic comfort
- Up to 4,500 lbs (2,043 kg) weight capacity keeps equipment safe
- Organize your equipment and tools for convenient access
- Easy assembly and modularity allows you to add additional units to create multiple workstations
- Front and Rear mounting slots allow component adjustability in 1- inch increments on both sides of frame
- Server shelves easily hold up to 500 pounds of equipment.
- Lockable casters enable quick system relocation
- All frame-mounted components have safety lock features
- Patented Quik-Touch cable management system, individually hinged sections to provide one-touch access.
- Rugged, durable construction and an Industry-leading warranty

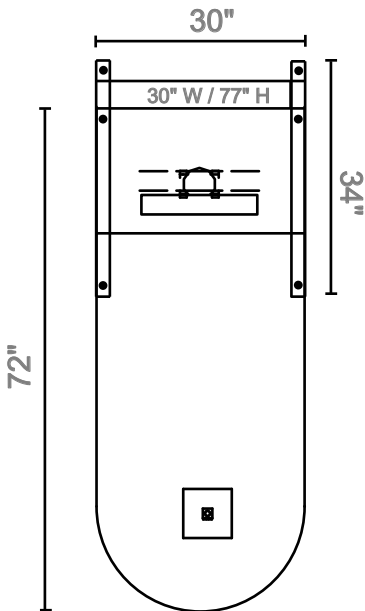
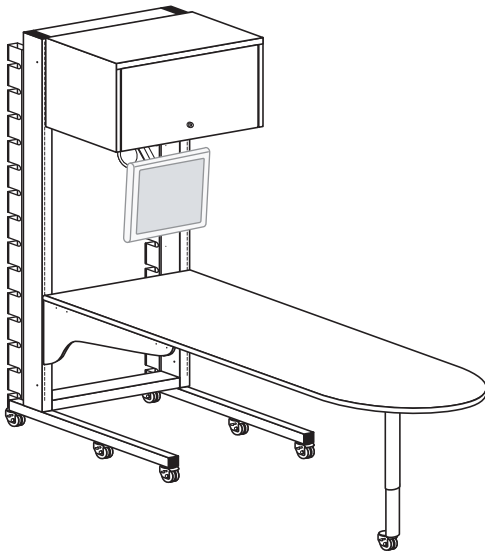

**Assembly Number: MILTS-27304-GY**

Dimensions: 30" W x 77 3/16"H x 37" D

Shipping Wt: 337

Weight Capacity: 1250 lbs

Color of Worksurface: Grey Nebula

Color of DuraFrame: Grey

Qt	Parts	Description	MSRP Ext	
1	MILTS-10063-GY	30"W x 77"H Duraframe	397	397
1	MILTS-17040-GY	34"L Legs, pair	225	225
1	MILTS-72022-XX	Casters, set of 6	134	134
1	MILTS-72003-XX	Caster, one	22	22
1	MILTS-55087-GY	30"W x 72"D Worksurface	303	303
1	MILTS-65069-GY	Cantilever Bracing, Single Frame	229	229
1	MILTS-65081-GY	Front Support Leg, Adj Height	205	205
1	MILTS-95011-GY	30"W Lockable Security Cabinet	514	514
1	MIFPA-45400-GY	Suspension Mount Flat Panel Arm	288	288
1	MILTS-42021-GY	Suspension Truck (for MIFPA-45400)	54	54
6	MILTS-70067-GY	36"L Quik-Touch Cable Management	30	180
4	MILTS-70068-GY	24"L Quik-Touch Cable Management	25	100
1	MIPWR-83125-XX	8-outlet power strip (24"L)(H-mount)	77	77
<b>Total:</b>			<b>2728</b>	

**Product Highlights**

- Suspended flat panel monitor allows easy adjustment by operator
- Lockable cabinets provide security for storage
- Up to 4,500 lbs (2,043 kg) weight capacity keeps equipment safe
- Organize your equipment and tools for convenient access
- Easy assembly and modularity allows you to add additional units to create multiple workstations
- Front and Rear mounting slots allow component adjustability in 1- inch increments on both sides of frame
- Server shelves easily hold up to 500 pounds of equipment.
- Lockable casters enable quick system relocation
- All frame-mounted components have safety lock features
- Patented Quik-Touch cable management system, individually hinged sections to provide one-touch access.
- Rugged, durable construction and an Industry-leading warranty